

Specifications:

MODEL		Smart-32	Smart-42	Smart-32T8	Smart-42T8
Max. swing over bed	mm	320	320	320	320
Max. turning diameter	mm	Ø200	Ø200	Ø200	Ø200
Max. turning length	mm	117	117	140	140
Max. bar capacity	mm	Ø32	Ø42	Ø32	Ø42
Bore of spindle	mm	Ø34	Ø44	Ø34	Ø44
Spindle bearing inside dia.	mm	Ø80	Ø80	Ø80	Ø80
Spindle nose		A2-5	A2-5	A2-5	A2-5
Spindle speed range	rpm	45~3500	45~3500	45~3500	45~3500
Spindle motor	kw	5.5	5.5	5.5	5.5
Max. travel X1/Z1-axis	mm	215/127	215/127	215/150	215/150
Rapid traverse X1/Z1-axis	mm	20"	20"	20"	20"
Turret indexing time	sec	-	-	0.3	0.3
Machine slant degree		20°	20°	20°	20°
Slide way type		Square guideway	Square guideway	Square guideway	Square guideway
3-jaw chuck size		6"	6"	6"	6"
Collet type	mm	163E	173E	171E	173E
Turning tool size	mm	□20	□20	□20	□20
Boring tool diameter	mm	Ø25	Ø25	Ø25	Ø25
Cutting tool size	mm	□20	□20	□20	□20
X/Z axis ball screw dia.	mm	Ø32	Ø32	Ø32	Ø32
X/Z axis feeding motor	kw	1.0/1.2	1.0/1.2	1.0/1.2	1.0/1.2
Hydraulic motor	kw	0.75	0.75	0.75	0.75
Lubrication motor	w	150	150	150	150
Power requirement	KVA	10	10	10	10
Coolant tank capacity	L	80	80	80	80
Machine dimensions (LxWxH)	mm	2813x1423x2100	2813x1423x2100	2813x1423x2100	2813x1423x2100
Weight	kg	2200	2200	2200	2200

* Our company reserves the right to change the specifications without notice.

Accessories list	SMART	32/42	32/42T8
Lighting device		○	○
Coolant device		○	○
Splash guard		○	○
Tools & Tool box		○	○
Base block		4 PCS	4 PCS
Inner cutting tool sleeve Ø8, 10, 12, 16, 20mm		○	○
Foot switch		○	○
Collet chuck holder		○	○
Double side inner tool holder (Gang type)		○	-
Inner cutting tool holder (Gang type)		○	-
External cutting tool holder (Gang type)		○	-
Tool holder down base block (Gang type)		○	-
Double side external tool holder (Gang type)		○	-
Heat exchanger		○	○
Material stop bar		○	-
Operation manual		○	○
NC control operation manual		○	○
NC control maintenance manual		○	○
8-position hydraulic turret		-	○
6" 3-jaw chuck		×	×
Material stop bar (turret)		-	×
ER20 collets set		×	×
3-inner tool holder		-	×
Chip conveyor		×	×
Parts conveyor		×	×
Chip cart		×	×
Parts catcher		×	×
2-position end drilling device		×	×
2-position side drilling device		×	×
8-position hydraulic servo turret		-	×
CE certification		×	×
6,000 RPM spindle speed		×	×
Transformer		×	×
Voltage stabilizer		×	×
Chuck air blow		×	×
5° multiple cycle setting device		×	×
Hydraulic bar feeder 1.2M		×	×
Hydraulic bar feed 3.2M		×	×

○: Standard ×: Optional -: Non



JINN FA MACHINE INDUSTRIAL CO., LTD.

No. 12, Hengzun Ln., Fusing Township,

Changhua County 50643, Taiwan.

TEL: 886-4-779-2211 (REP)

FAX: 886-4-779-3386

http://www.jinnfa.com

E-mail: jinnfa@ms18.hinet.net



SMARTseries

The Most **Economical** Compact **CNC Lathe**
The Compact CNC Lathe with Added Value





MODEL IDENTIFICATION

SMART-

Type 32

Type 42

T8:8 Position hydraulic turret
OMIT: Gang type tooling system

SMART series

The SMART series CNC lathe lets you enjoy extraordinary precision and productivity. When you select SMART series, you get more than greater production. You also get all the traditional JINN FA quality, and consistent machining performance. The machine features high speed and lower production costs for bar machining. Upon request, the machine is available to equip with bar feeder and parts catcher for increasing production efficiency.



**Rigid Structure!
High Positioning Accuracy!
Profitable Machining!**

SMART series



TURRET TYPE WITH 3 POSITION GANG TOOL HOLDER

Which tooling system do you choose on a CNC automatic lathe? Now it is possible to get them both on the specially designed SMART series, which greatly reduces your machining time.



GANG TYPE WITH 2 POSITION POWER TOOLS

The gang type tooling system consists of 6 tools. Tool change is fast and conveniently accomplished. This combined with 2-position powered tools enables the machine to perform face milling, drilling and tapping operations.



SLANT BED AND RUGGED BASE

The 20° slant bed structure not only facilitates chip disposal, but also allows easy access to the workpiece. The ruggedly constructed base assures maximum rigidity and stability in heavy duty machining.

PARTS CATCHER

Upon request, a parts catcher is available. It provides convenient and efficient parts collection.

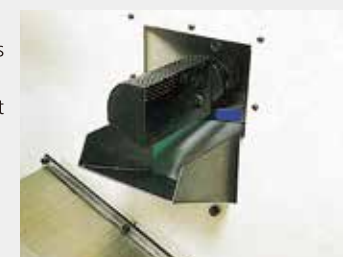

JINN FA CNC Lathes Designed for Profitable Production

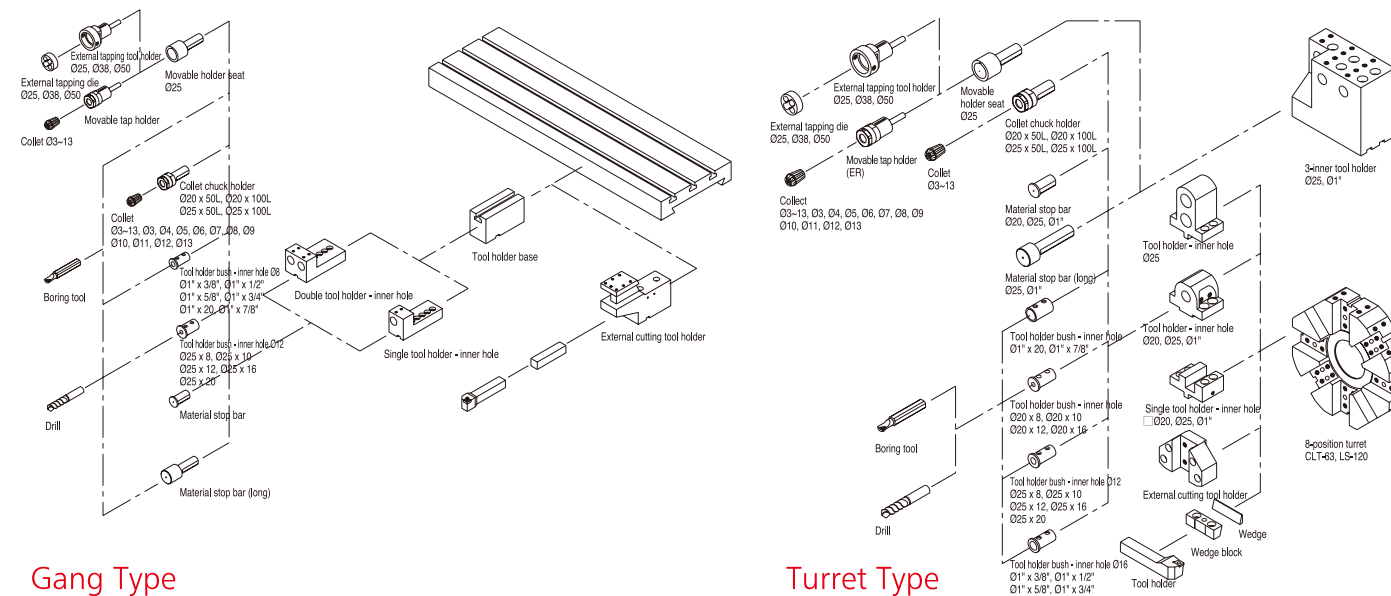

Gang Type

Turret Type

